



# KLINGER FLUID CONTROL

With passion  
for outstanding quality



# KLINGER GROUP

trusted.worldwide.

As one of the world's leading quality manufacturers and suppliers of seals and valves KLINGER runs production locations, distribution and service centres in over 40 countries. We boast a track record of over 125 years. Our flexibility, know-how and pioneering spirit let our Group self-confidently face any challenge of traditional and new markets. The KLINGER brand is the epitome of technical

reliability, power of innovation and highest quality. Products and processes accurately tailored to our customers' needs allow us to meet strictest requirements in an international market environment.

€ 420 million annual sales

In fiscal year 2016, the KLINGER Group generated sales of 420 million euros.



2,300 employees

Our global workforce amounts to 2,300 persons worldwide



80 destination countries of the Group's previous exports



19 production locations worldwide



for seals, valves and instrumentation



60 countries worldwide are home to a Group subsidiary or representative

# KLINGER FLUID CONTROL

Today for tomorrow

As a subsidiary of the KLINGER Group, KLINGER Fluid Control has been developing, manufacturing and maintaining high-quality industrial valves at the business location Gumpoldskirchen/Austria for more than 125 years. Via the global distribution and service network, KLINGER Fluid Control offers both standardized and tailored products, services as well as solutions for customers around the globe.

Products from KLINGER Fluid Control are characterized by their high level of reliability as well as by an above average lifecycle at a simultaneously very low total cost of ownership (TCO). As a trusted solutions partner, KLINGER Fluid Control creates customer benefits with added value. In this regard, the focus is on the following core competences:



## ENCOMPASSING SERVICE

- » Application expertise
- » Product trainings
- » Fast quotation and order processing
- » Customer-specific special solutions
- » Supply of spare parts
- » Valve maintenance
- » On-site technical support

## INNOVATIVE SOLUTIONS

- » State of the art development tools
- » Product development for different areas of application
- » Customer-specific special solutions
- » Automation solutions
- » Product tests in the company-own technical center
- » A wide range of certificates and approvals

## OPERATIONAL EXCELLENCE

- » Flexible production
- » Transparency in the supply chain
- » Short delivery times
- » ISO 9001 certified quality
- » ISO 14001 as well as EMAS certified environmental management system

# PRODUCT OVERVIEW

Ballostar® KHI ball valves

» 06

Monolith KHO ball valves

» 08



Ballostar® KHE ball valves

» 14

KVN piston valves

» 16



## APPLICATIONS



INDUSTRY



OIL & GAS



CHEMICAL



INFRASTRUCTURE



ENERGY



PHARMA

» Monoball® KHM ball valves

» 10

» Ballostar® KHA ball valves

» 12

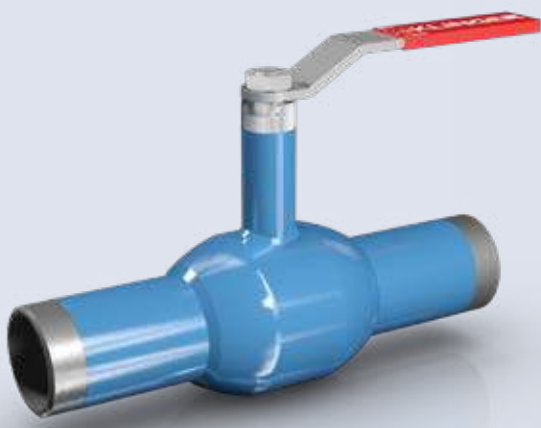

» Butterfly valves  
Conaxe

» 18

» AB-cocks  
and Gauge-glasses

» 20



PULP & PAPER

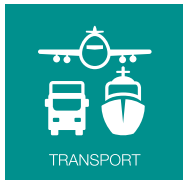

TRANSPORT

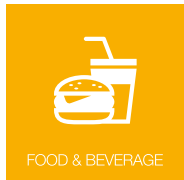

FOOD & BEVERAGE

# BALLOSTAR® KHI

Decades of reliability guaranteed

## BALLOSTAR® KHI

KLINGER Ballostar® KHI ball valves will keep up with stricter requirements and are assured to already meet future standards with regard to tensile, compressive and bending stress. Its unique sealing system is another feature of Ballostar® KHI. The test and drain valve welded to the ball valve housing allows the pressure to be relieved intermediately while the ball is closed. The key benefit of this feature is that Ballostar® KHI can be leak-tested at any time without having to open the pipeline. These ball valves are fit for many different applications such as underground district heating trenches, buried pipelines, co-generation power stations, pump stations, steelworks, hydroelectric power stations and tunnel boring machines.



## PRODUCT ADVANTAGES

- » Maintenance-free
- » Supports pressurisation on either side
- » Trunnion-mounted ball with cylindrical full-passage duct
- » Bidirectional sealing to EN 12266 – leakage rate A
- » Sealing elements protected against surge pressure
- » Double block and bleed with intermediate venting (TÜV-certified)
- » Highly resistant to piping forces
- » Tested and certified to EN488:2015 (VVS)
- » Subsequent automation possible at any time (top flange to EN ISO 5211)

## SPECIAL TYPES

- » High temperature version (up to +260 °C)
- » Special design for tunnel boring machines
- » Pre-insulated design for underground installations (KHSVI VVS)
- » Special ball coatings
- » Metal seat for abrasive media
- » Oxygen version
- » Fire Safe version
- » Vacuum version
- » Gas version
- » Oil, grease and silicone-free

## PRODUCT DETAILS

PN	16/25/40
DN	150 – 1000
Material	Cast steel, corrosion-proof and acid-proof cast steel, special materials upon request
Temperature	-45 °C to +260 °C
Design	Flanges, welding ends, fully welded (KHSVI VVS), reducing cones, full and reduced bore
Type	Two-piece ball valve KHI / KHSVI Single-piece ball valve KHSVI VVS

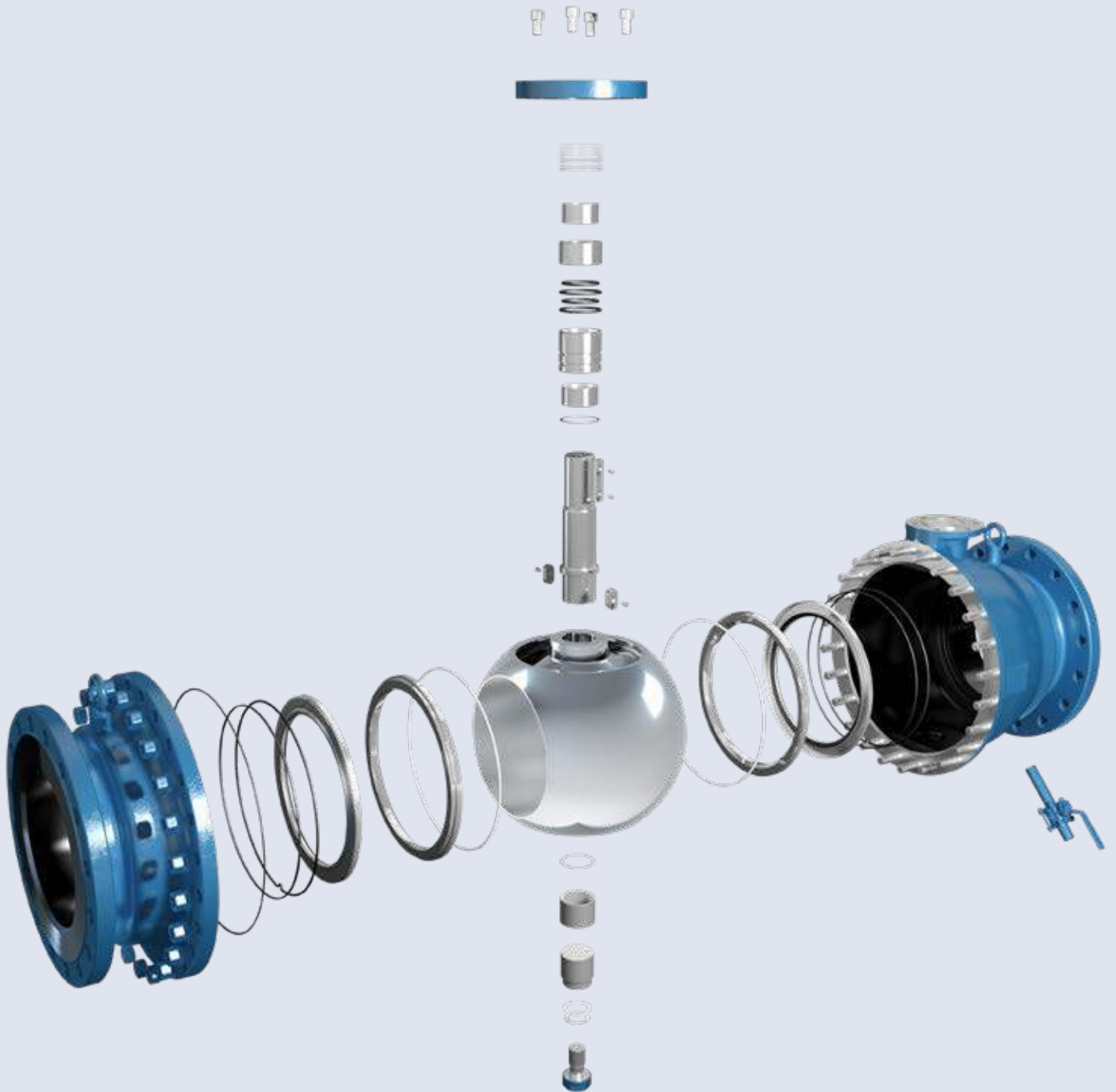

Ballostar® KHI » Screwed design with flanged ends

# MONOLITH KHO

Tough ball valve for harshest service conditions

## MONOLITH KHO

The KLINGER Monolith KHO withstands the highest tensile and compressive forces as well as bending torques generated by pipelines. FEM calculations were applied to design and optimise the entire construction.



## PRODUCT ADVANTAGES

- » Maintenance-free
- » Supports pressurisation on either side
- » Long heat-insulating shaft
- » Double-supported, blowout-proof operating stem
- » Multiple long-life stem seals
- » Highly resistant to piping forces
- » Tested and certified to EN488:2015
- » Meets the requirements of AFGW FW 401 – Part 5
- » Elastically pre-stressed sealing elements with stainless steel sine springs
- » Trunnion-mounted ball (DN200 or higher)
- » Stainless steel stem and shaft end

## SPECIAL TYPES

- » Pre-insulated design for plastic casing pipe systems
- » Available in different shaft lengths
- » Top flange in accordance with EN ISO 5211 for automation
- » Full solution with insulation extension, venting and bleeding, insulation and alert system

## PRODUCT DETAILS

PN	25/40
DN	25 – 300
Material	Cast steel, special materials upon request
Temperature	-10 °C to +200 °C
Design	Welding ends, for underground installation, full and reduced bore
Type	Fully welded ball valve





# MONOBALL® KHM

Versatile product for tailored solutions

## MONOBALL® KHM

KLINGER Monoball® KHM is a fully welded single-piece ball valve. The ball valves of this series have been uncompromisingly designed for their functionality in district heating, heating and air-conditioning systems or in general plant engineering. Apart from a wide range of standard versions, there are also various special Monoball® designs. They include a special version for buried applications for use in plastic casing pipe systems or buried draining and venting installations.

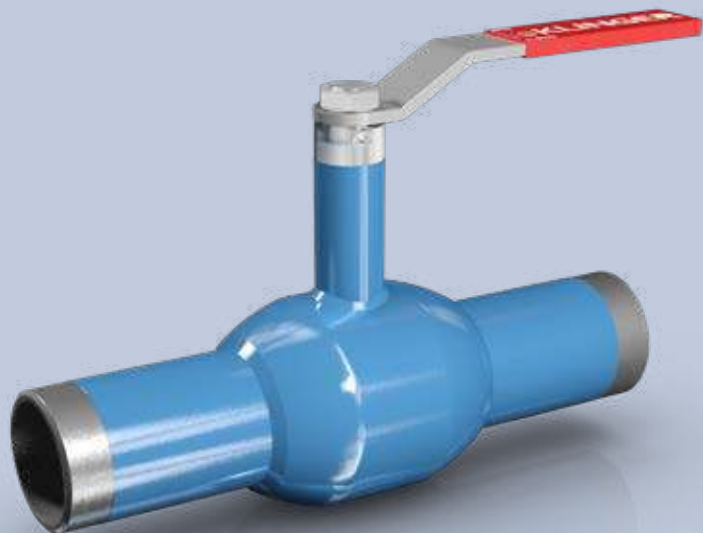

## PRODUCT ADVANTAGES

- » Maintenance-free
- » Supports pressurisation on either side
- » Long heat-insulating shaft
- » Many fully interchangeable link-up versions
- » Multiple long-life stem seals
- » Double-supported, blowout-proof operating stem
- » Stainless steel stem prevents contact corrosion
- » Elastically pre-stressed sealing elements with stainless steel belleville springs
- » Tested and certified to EN488 and FW401 – Part 5
- » Automation-ready (DN100 or higher with full bore)

## SPECIAL TYPES

- » Pre-insulated version for plastic casing pipes
- » Pre-insulated draining and venting adapters made of stainless steel for plastic casing pipe systems
- » Twin set with wall bracket
- » Special lengths
- » Topping valves (matching Hütz und Baumgarten's topping device)
- » Branching ball valves

## PRODUCT DETAILS

PN	16/25/40
DN	DN 10 – 150 (larger sizes on request)
Material	Carbon steel and stainless steel
Temperature	0 °C to +200 °C
Design	Welding ends, flanges, threaded connection, male thread and combinations, full and reduced bore, hand lever, hexagon socket, buried installations
Type	Single-piece ball valve

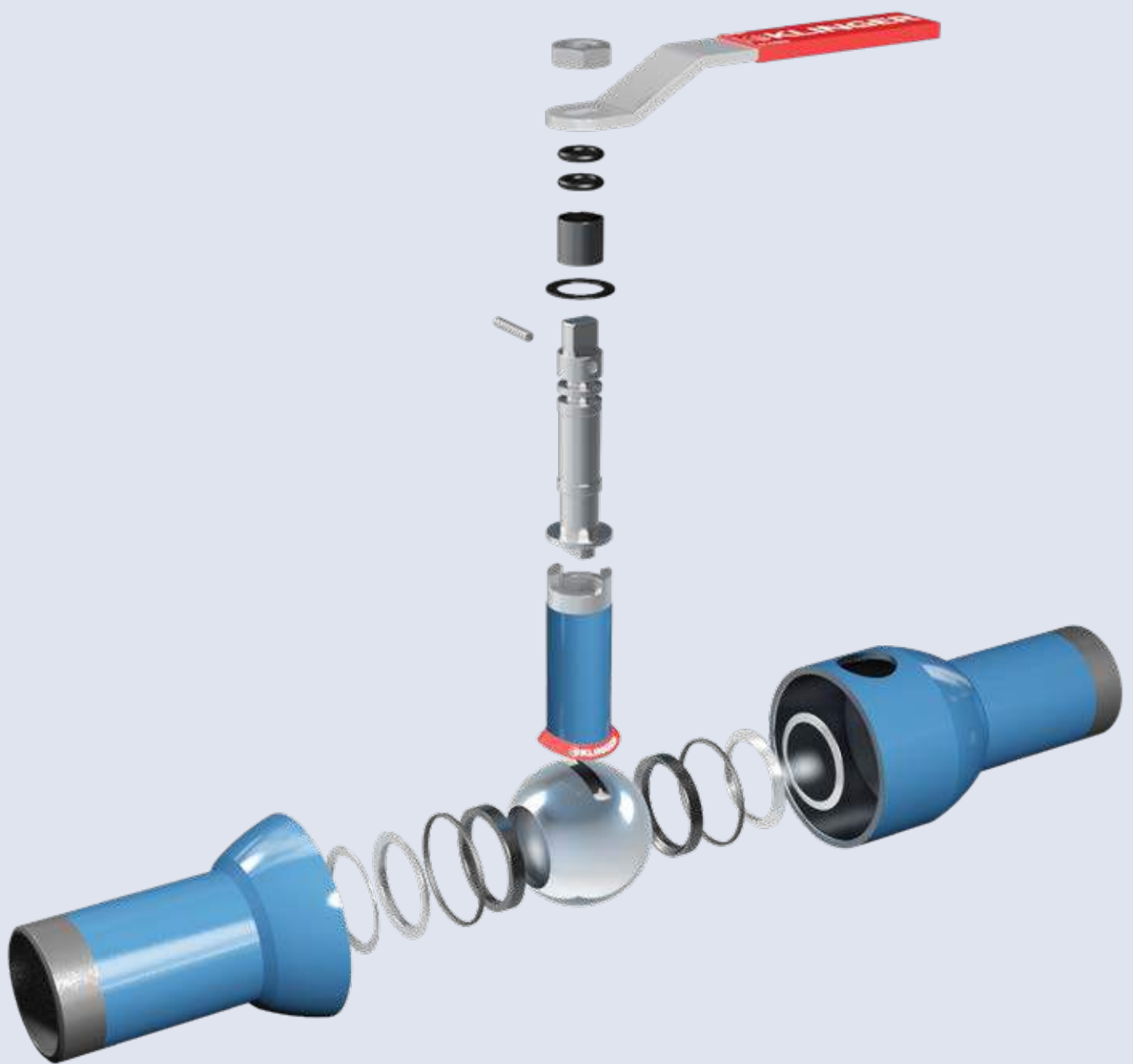

# BALLOSTAR® KHA

Kit for many applications

## BALLOSTAR® KHA

KLINGER Ballostar® KHA ball valves consist of a modular construction kit which results in a great multiplicity of versions. Different link-up options can be combined and several types of sealing elements and shaft seals installed to ensure that the Ballostar® KHA series ball valves are general-purpose devices for almost any application.



## PRODUCT ADVANTAGES

- » Maintenance-free
- » Supports pressurization on both side
- » Bidirectional flow
- » Ball with a cylindrical full bore
- » Unique pre-stressed and elastic sealing system
- » Bidirectional sealing in accordance with EN 12266-1 – leakage rate A
- » Modular selection of system components
- » Serviceable without removal from the line
- » Antistatic design in accordance with ISO 7121 / EN 1983
- » Subsequent automation possible at any time (top flange in accordance with EN ISO 5211)

## SPECIAL TYPES

- » Metal seat (up to +400 °C) for abrasive media
- » Operating stem sealed by O-rings
- » Operating stem extension
- » Oxygen version (oil, grease and silicone-free)
- » Cryogenic version (down to -196 °C)
- » Fire-Safe version
- » Vacuum version
- » Gas version

## PRODUCT DETAILS

PN	16/25/40/63/100
DN	10 – 125
Material	Cast steel, corrosion-proof and acid-proof cast steel, cast iron, nodular cast iron, special materials upon request
Temperature	-196 °C to +400 °C
Design	Flanges (long, short), threaded connections, welding ends (long, short), full and reduced bore
Type	Three-part ball valve

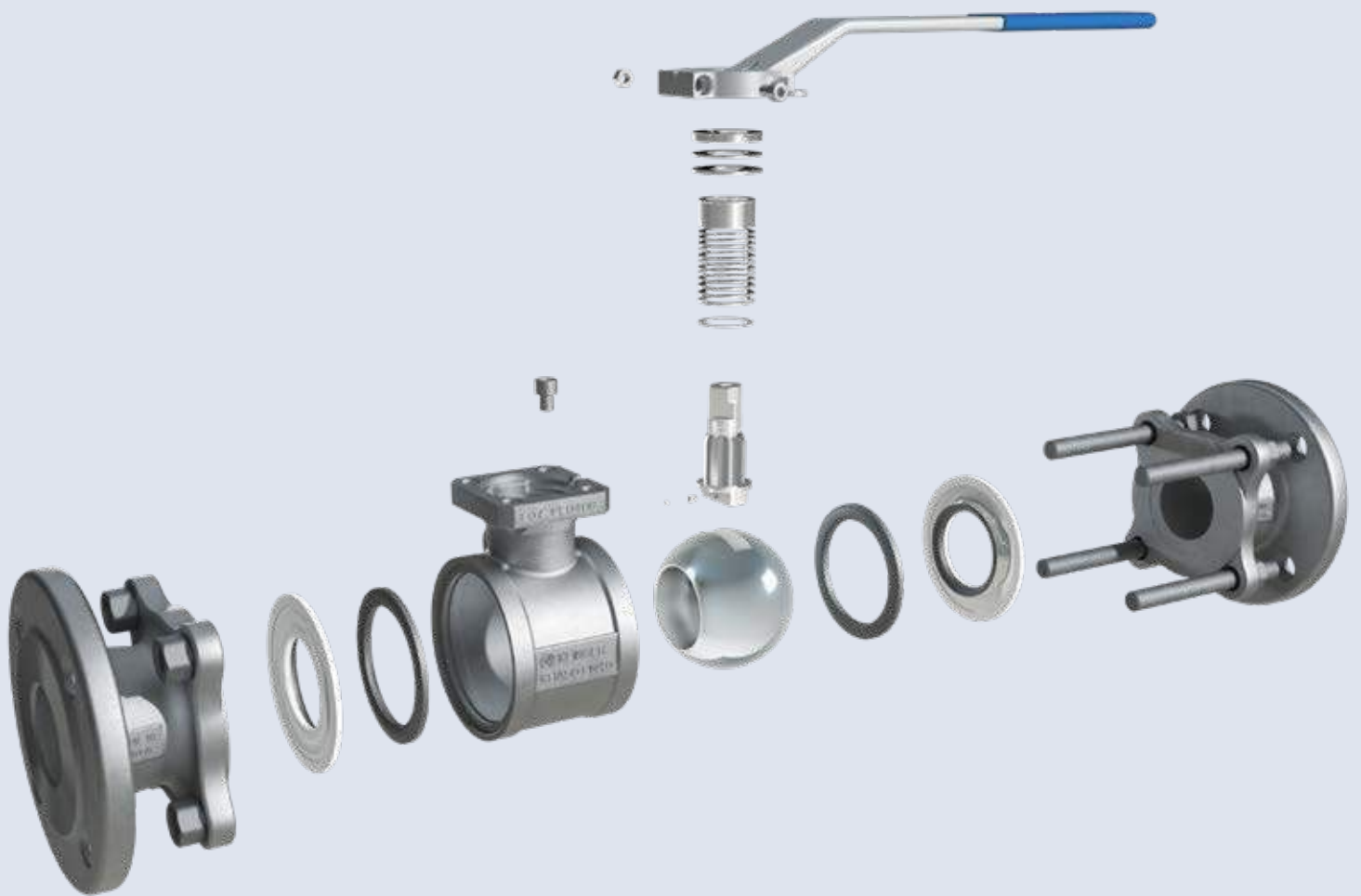

# BALLOSTAR® KHE

Compact valve for universal use

## BALLOSTAR® KHE

Owing to its different housing and sealing materials, KLINGER Ballostar® KHE can be used in a great many different applications. Thus, choosing the right modular system components yields a solution that accurately meets your requirements. Many different approvals warrant a high level of operational safety. Our ball valve series made to ASME standards would not be complete without a wide range of rated DIN widths of flange fittings.



## PRODUCT ADVANTAGES

- » Maintenance-free
- » Supports pressurization on both sides
- » Ball with cylindrical full bore
- » Sealing in accordance with EN 12266-1 – leakage rate A
- » Modular selection of system components
- » Fire Safe
- » Antistatic design in accordance with ISO 7121 / EN 1983
- » Subsequent automation possible at any time (top flange in accordance with EN ISO 5211)
- » Optimal spare parts availability (as a result of common parts with Ballostar® KHA)

## SPECIAL TYPES

- » Metal seat for abrasive media
- » Operating stem sealed by O-rings
- » Operating stem extension
- » Oxygen version (oil- and grease-free)
- » Gas version

## PRODUCT DETAILS

PN	16/40, Class 150/300
DN	15 – 200, ½" – 8"
Housing	Cast steel, stainless steel, special materials upon request
Ball	Stainless steel
Operating Stem	Stainless steel
Temperature	-60 °C to +300 °C
Design	Flanges (long, short), full bore
Type	Two-piece ball valve

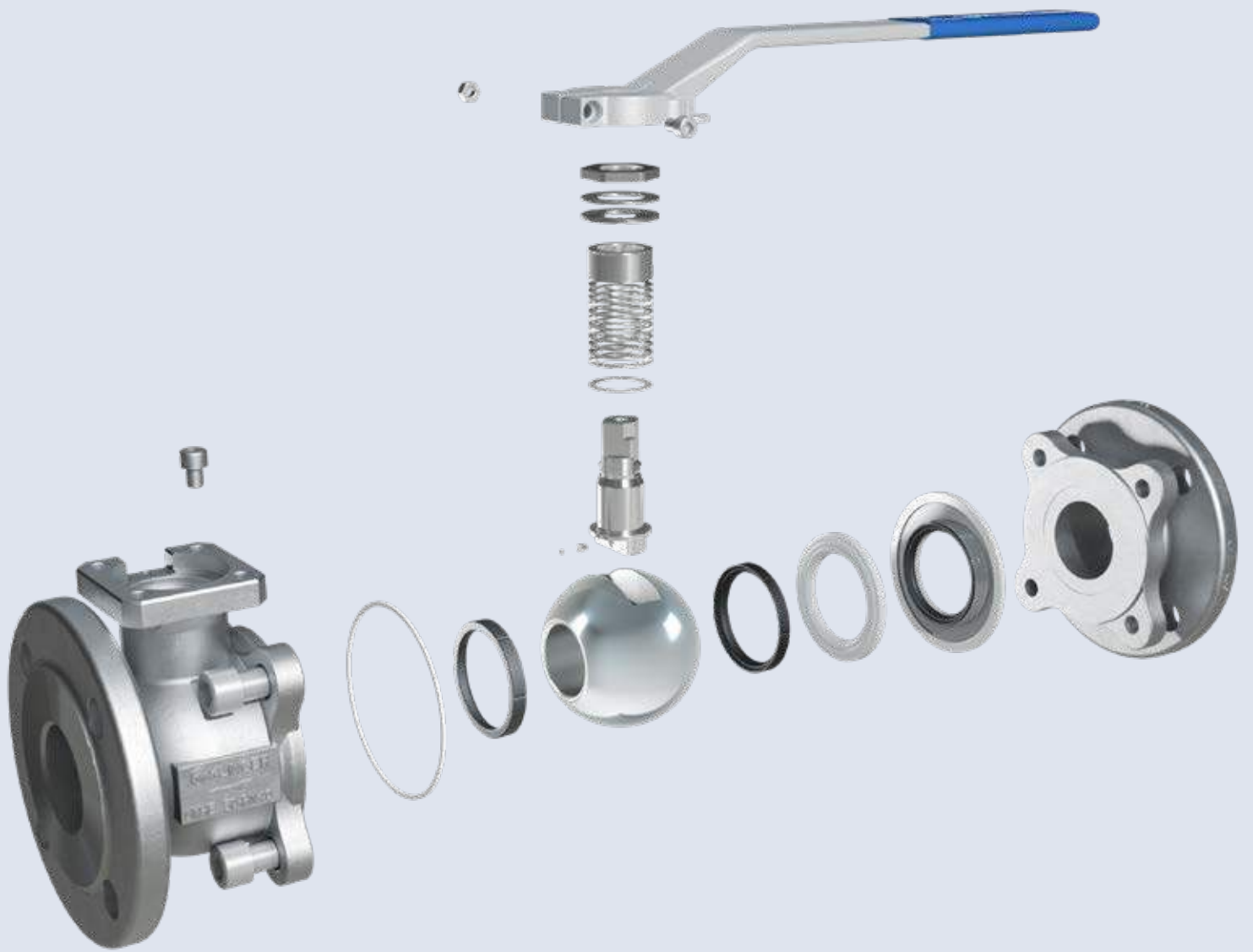

# KVN PISTON VALVE

The endlessly tried and tested original

## KVN

Due to constant technical product improvement, KLINGER has been and remains to be one of the leading manufacturers of piston valves. Different types of connections as well as DIN and ASME-compliant designs ideally supplement KLINGER's wide range of industrial valves.



## PRODUCT ADVANTAGES

- » Excellent regulating characteristics
- » Sealing in accordance with EN 12266-1 - leakage rate A
- » Suitable for alternate steam/condensate operation
- » as well as for thermal shock operations
- » Special sealing elements for highest operation cycles
- » Impervious to dirt
- » Serviceable without removal from the line
- » Fire Safe
- » Automation-ready

## SPECIAL TYPES

- » Oxygen version (free from oil, grease and silicone)
- » End position detection (mechanical and inductive)
- » "TA-Luft"
- » Heating jacket
- » ISO flange for mounting of actuator
- » Regulating Version

## PRODUCT DETAILS

PN	16/40/63, Class 150/300
DN	15 – 200, 1/2" – 8"
Material	Grey cast iron, nodular cast iron, cast steel, stainless steel
Temperature	-10 °C to +400 °C
Design	Flanges, threaded connection, socket weldends, butt weldends
Type	Piston valve





# BUTTERFLY VALVE CONAXE

Durability for numerous applications

## CONAXE

With the Conaxe, KLINGER Fluid Control offers a tried and proven double offset high-performance butterfly valve for demanding applications. These include, amongst others, the energy and district heating sector, the oil industry, the chemical industry as well as both the paper and the steel industry.

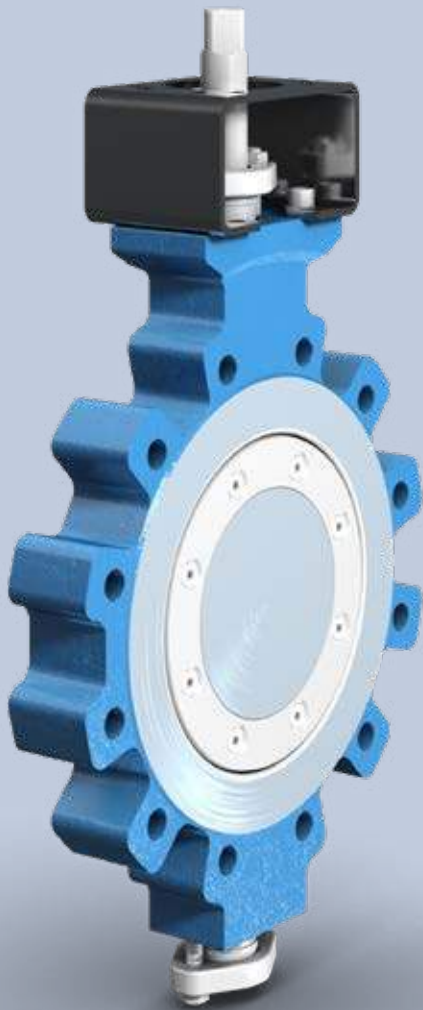

## PRODUCT ADVANTAGES

- » Maintenance-free
- » Least pressure losses due to split shaft
- » Low actuation torque due to optimized seat geometry
- » Sealing in accordance with EN 12266-1 – leakage rate A (soft seated)
- » Bidirectional flow (soft seated)
- » Optimum force transmission and significantly higher load capacity due to polygon connection
- » Serviceable without removal from the line
- » Subsequent automation possible (top flange in accordance with EN ISO 5211)
- » Wear and corrosion-resistant seat

## SPECIAL TYPES

- » Metal seat for abrasive media and up to 280 °C (unidirectional sealing)
- » Fire Safe version
- » Oil, grease and silicone-free
- » Cryogenic version down to -196 °C
- » Further tailored solutions upon request

## PRODUCT DETAILS

PN	10/16/25/40, Class 150/300
DN	50 – 1300
Material	Carbon steel, stainless steel, further materials upon request
Temperature	-196 °C to +280 °C
Design	Lug, wafer, welding ends, flanges
Type	Double offset high-performance butterfly valve

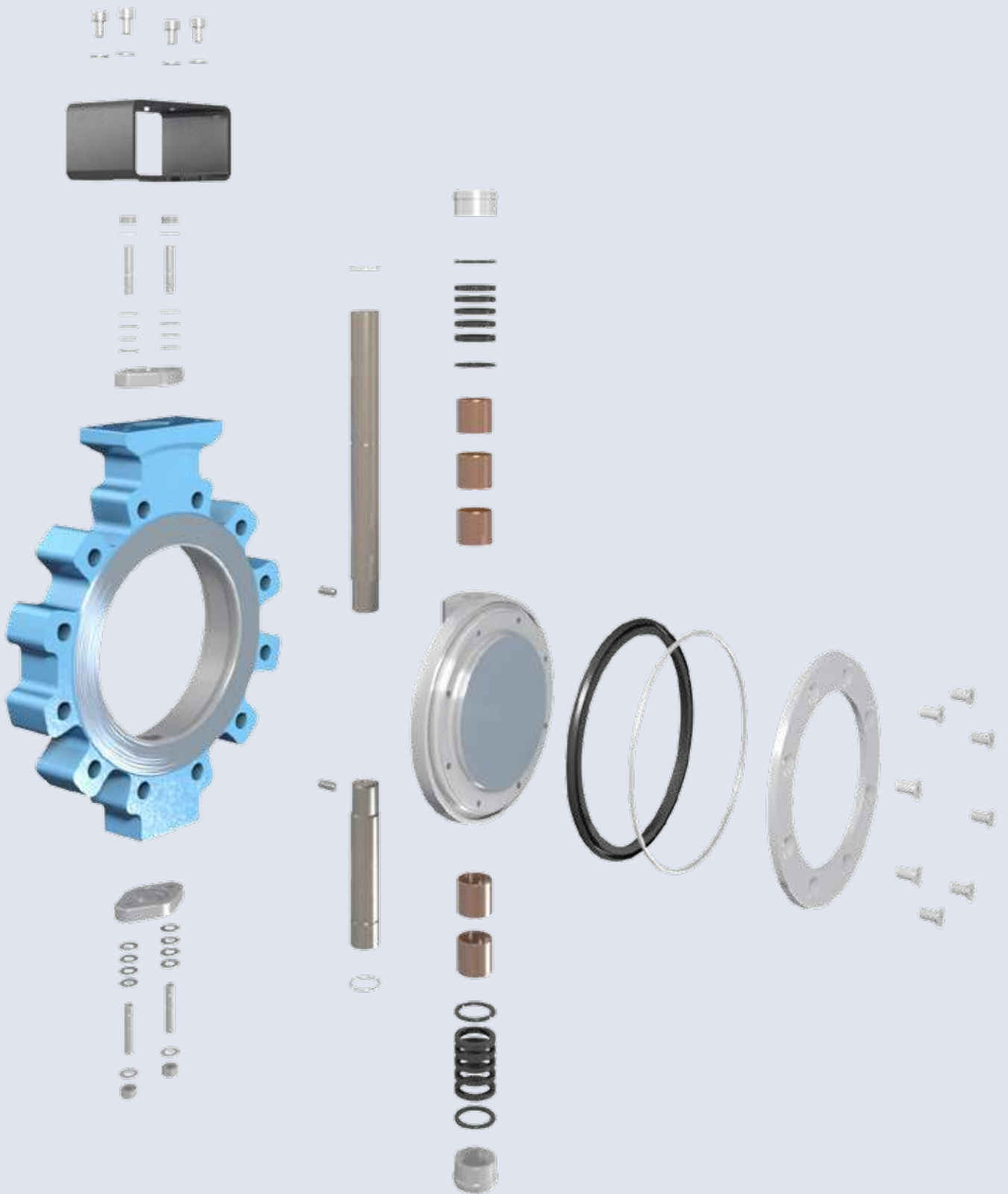

# BOROSILICATE GAUGE GLASSES

Withstands the harshest conditions

## BOROSILICATE GAUGE GLASSES

The quality of a gauge glass mainly depends on its chemical composition and the mechanical strength of the glass material.

Analysing the glass by taking acid and base samples assures a uniform quality of the gauge glasses. Their mechanical strength is provided by heat-strengthening.

## APPLICATIONS

- » Refineries
- » Petrochemistry
- » Pharmaceutical industry
- » Chemical engineering
- » Mechanical engineering, particularly boiler and vessel engineering
- » Foodstuffs and beverages industry
- » Water supply and distribution
- » Paper and pulp production
- » Textile industry
- » Maritime industry

## PRODUCT DETAILS

Design	Reflex gauge glass, transparent gauge glass, circular gauge glass
Material	“Extra strong” borosilicate
Temperature	-273 °C to +400 °C
Mica	For transparent gauge glasses
Spare parts sets	Available with KLINGER Sil seals



In langer und runder Ausführung

# AB-COCKS

Reliable and fail-proof shut off

## » AB-COCKS

AB-cocks are simple and extremely sturdy shut-off valves designed with the very specific needs of measuring technology in mind. Their unfailing operation and economic efficiency have earned them millions of practical applications worldwide.

## » PRODUCT ADVANTAGES

- » A generously sized sealing face ensures that the bore is reliably sealed and that measuring errors on the outside are prevented
- » Manual operation supported in throttle position
- » Simple design (just one moving part) for high-level operational safety
- » The sealing bush - the valve's only wearing part - can be replaced within a few minutes without having to remove the AB cock from the pipeline.
- » Special designs are available for pressure gauges, indicators and liquid level gauges

## » PRODUCT DETAILS

PN	40/160/250
Design	ABM, MABA, ABI, ABZ etc.
Material	Brass, steel and stainless steel
Temperature	-200 °C to +400 °C
Variants	Various link-up types: Ermeto, Maihak, Burmeister, etc., Sealing bushes available in PTFE, KAF, KOR-AF



# GLOBAL NETWORK OF PARTNERS

Our know-how near you

## EUROPE

Austria  
**KLINGER Gebetsroither**

Belgium  
**KLINGER Sogefiltres**

Bulgaria  
**Polymat**

Croatia  
**Tehnotrade D.O.O.**

Czech Republic  
**Ruml spol s.r.o**

Denmark  
**KLINGER Danmark A/S**

England  
**Valveforce**

Finland  
**KLINGER Finland**

France  
**KF Fluid**

Germany  
**KLINGER Fluid Control**

Germany  
**KLINGER Schöneberg**

Greece  
**Chryssafidis S.A.**

Hungary  
**Soltész + Soltész**

Iceland  
**EP Verk**

Italy  
**KLINGER Italy s.r.l.**

Netherlands  
**KLINGER BV**

Norway  
**Bagges AS**

Poland  
**KLINGER w Polsce Sp.z.o.o.**

Portugal  
**KLINGER Portugal Lda.**

Romania  
**Rom Energy Armstrong**

Russia  
**Ingcom**

Serbia  
**Ninacom D.O.O.**

Slovakia  
**S Armat**

Slovenia  
**Trimad D.O.O.**

Spain  
**Saidi**

Sweden  
**KLINGER Sweden**

Switzerland  
**Franz Gysi AG**

Ukraine  
**Emerald-Technique LCC**

Turkey  
**Isik**

## AFRICA

Egypt  
**Nesco**

Israel  
**Transtecnica Fluid Control**

Ivory Coast  
**Trouvay-Cauvin Afrique**

Southafrica  
**KLINGER (Pty) Ltd**

VAE  
**Ados**

## ASIA

China  
**KLINGER Shanghai**

China  
**Sunitex**

India  
**Glasstech**

India  
**H.R.S.**

India  
**Uni KLINGER**

Indonesia  
**Trimitra Wisesa Abadi**

Iran  
**Klingeran**

Japan  
**Bunkaboeki Kogyo**

Malaysia  
**Pacline**

Pakistan  
**Adenwalla & Sons**

Pakistan  
**Industrial Equipment**

Pakistan  
**Nova Engineering**

Philippines  
**Mheco**

Singapore  
**Gumpold Fluid Controls**

South Korea  
**Samkyong**

South Korea  
**Specs Corporation**

Sri Lanka  
**Ruby**

Taiwan  
**Sunny Brico**

Thailand  
**Alpha Group**

Vietnam  
**Southern Technology**

## AUSTRALIA

Australia  
**KLINGER Ltd**

## NORTH AMERICA

Canada  
**A-Chem Group**

USA  
**KLINGER Advantage**

## SOUTH AMERICA

Argentina  
**Rich. KLINGER S.A.A.C.I. y F**

Brazil  
**Richard KLINGER**



**GUMPOLDSKIRCHEN  
AUSTRIA**



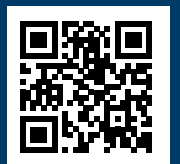

Your KLINGER distribution partner

Edition 2018 | Typing and printing errors reserved

KLINGER Fluid Control GmbH  
Am Kanal 8-10 » 2352 Gumpoldskirchen » Austria  
Tel: +43 2252 600-0 » Fax: +43 2252 600-100  
office@klinger.kfc.at

[www.klinger.kfc.at](http://www.klinger.kfc.at)